

EMPFOHLENE VORSICHERUNG						
QUERSCHNITTS- FLÄCHE . . MM2						
ZABEZPIECZENIE	16 A	20 A	25 A	35 A	50 A	63 A
LEITUNGSLÄNGE						
- 10 M	2.5 MM2	2.5 MM2	4.0 MM2	6.0 MM2	10.0 MM2	16.0 MM2
10 - 20 M	2.5 MM2	4.0 MM2	4.0 MM2	6.0 MM2	10.0 MM2	16.0 MM2
20 - 30 M	2.5 MM2	4.0 MM2	4.0 MM2	6.0 MM2	10.0 MM2	16.0 MM2

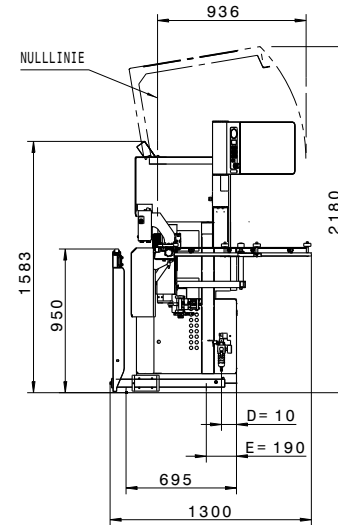

E= PRZYŁĄCZE ELEKTRYCZNE  
 NAPIĘCIE ROBOCZE  
 400V - 3PH - 50HZ  
 ŁĄCZNA MOC PRZYŁĄCZENIOWA  
 16 KW  
 PRĄD ZNAMIONOWY  
 23 A  
 CIĘŻAR  
 1850KG

D= DRUCKLUFTANSCHLUSS  
 6BAR / ø1/4"  
 GESAMTABSUGLEISTUNG  
 4480 M3/H

PRĘDKOŚĆ POWIETRZA  
 28M/ SEC  
 UBYTEK CIŚNIENIA  
 CA. 2000PA  
 ZUŻYCIE POWIETRZA  
 350 Nl/min

NUMER MASZYNY: **0-261-20-6472**

M		MATERIAL	-
1:20		GUSSMODELL	
		kg	dm <sup>3</sup>
PLAN USTAWIENIA		BRANDT	
AMBITION 1440 FC		ZEICHNUNG-NR.	
ISO 2768 mK-E		5-701-80-4049	
EN ISO 13920 -BE		A2	



OPTIMAT KDF 440 C

5-701-80-4049

DOKUMENTACJA D.03

